

# **audio research**

H I G H D E F I N I T I O N<sup>®</sup>

3900 ANNAPOLIS LANE NORTH / PLYMOUTH, MINNESOTA 55447-5447 / PHONE: 763-577-9700 FAX 763-577 0323

SP-8 PREAMPLIFIER  
OWNER'S MANUAL  
(All Versions)

Schematics Included: 7-1-81  
7-1-83  
4-4-84

TABLE OF CONTENTS

<u>SECTION</u>	<u>PAGE</u>
INTRODUCTION	1
PACKAGING	1
INSTRUCTIONS	1-3
SERVICING	3
MUTING PROVISIONS	4
SUMMARY OF FEATURES	4-5
WARRANTY TERMS AND CONDITIONS	6-7
WARRANTY OUTSIDE THE USA	7
SPECIFICATIONS	8
ADDENDUM: SCHEMATIC & PARTS LIST	

## INTRODUCTION

Congratulations on your purchase! Your SP-8 combines the highest possible musical fidelity with a new level of reliability and serviceability.

With the introduction of power amplifiers such as the D-40, D-79B, D-90 and D-120, and the availability of a number of brands of high performance recordings, pickups and speaker systems, the need for a new and higher level of preamplifier for the best systems has occurred.

After a significant amount of research and study we have determined that from a performance standpoint once again, the vacuum tube must be used.

For best results, only high quality turntables with stable pickup arms and cartridges should be used with this preamplifier.

We suggest that the SP-8 preamplifier will provide state-of-the-art reference indefinitely. We further suggest that inclusion of this unit in any otherwise good music reproducing system will effect more improvement than any other single component change.

For further discussion of performance and system requirements we encourage you to see your Audio Research dealer.

## PACKAGING

Save all packaging. Your Audio Research® preamplifier is a precision electronic instrument and should be properly cartoned any time shipment is made. You may never have occasion to return it to the factory for service, but if that should prove necessary, or other occasion to ship it occurs, the original packaging may save your investment from unnecessary damage or delay.

## SP-8 INSTRUCTIONS

The front panel has a total of 4 controls and 4 switches:

GAIN: This controls volume or loudness, and is a special metal film segmented control with approximately 2dB steps and accurate tracking. Although useable results can be obtained with settings anywhere in the operating range, more convenient control, best sound quality and signal-to-noise ratio will be obtained if the input signal levels and amplifier input sensitivity allow normal listening to occur in the 11 o'clock to 2 o'clock range of the volume control.

In the case of some high efficiency speakers (such as Klipschorn, etc.) and/or high output cartridges, it may be found with some high gain amplifiers (that do not have an input volume control) that normal listening will occur with the gain control just barely on, or up to the 9 o'clock position. If this proves to be the case, there is provision internally to reduce the gain by 6dB. Contact your Audio Research dealer or ARC's Customer Service Department for instruction.

BALANCE: A conventional stereo control. Moves the sound from left to right or vice versa when rotated. Normally should remain centered.

MODE: Also a conventional stereo control. Allows operation as indicated.

INPUT SELECTOR: Chooses between various possible source material for listening choice.

The "phono" input is an RIAA compensated high gain input for use with most magnetic cartridges. The input is 50K ohms, with very low (40 pF) input capacitance. If your cartridge needs more capacitance, there is built-in provision to add whatever is required. Contact your Audio Research dealer or our Customer Service Department if you need help with this.

PRE-AMP ON SWITCH AND INDICATOR: Turns the unit on in the up position, and the associated green LED will light up indicating that power is reaching the unit. During the 2-minute warmup period of automatic mute the green LED will illuminate, indicating the unit is on; however, the unit will not operate.

OUTLETS ON: Turns the power receptacles on the rear chassis panel on in the up position, and the associated LED will light up indicating that they are on. This switch is specifically provided to allow the amplifier to be turned on after the preamplifier is "warmed up." A vacuum tube device requires up to several minutes to fully stabilize its operating parameters. Power amplifiers should be turned off with the outlet switch before the SP-8 is turned off to avoid turn-off thumps. The SP-8 mutes just after turn-off to minimize any excessive output surges.

MUTE OPERATE SWITCH: Shorts the output of the preamplifier for the warmup (and cooldown) period. Also, to allow changing records (and maintaining a previous gain setting), answering the telephone and the like.

INPUT MONITOR: Primarily aimed for use with tape recorders, but may be used with any line level signal source where bypassing the input selector is desirable.

The rear panel has 4 power receptacles, a fuse holder, a ground terminal, 4 output jacks, 12 input jacks and a pair of banana jacks:

RECEPTACLES: There are two unswitched outlets which may be used for turntables and the like, where switching is not needed or wanted. There are also two outlets, relay controlled, capable of providing power to large amplifiers and the like. Incidentally, the "click" you hear internally when activating the receptacle switch is the relay operating. (The line cord is a 3 conductor, #14 gauge, providing ample safe grounded power to these 3 outlets.)

It should be noted that the SP-8 line cord grounds the convenience outlet grounds only. The preamplifier chassis is not connected to the line cord ground in order to minimize system ground loops.

FUSE: Always use the same size and type as indicated on the rear of the chassis for safety. For best results use Buss MDL or MDX fuses.

OUTPUT CONNECTORS: Main outputs should be connected to your power amplifier inputs. Tape outputs should be connected to your tape recorder AUX inputs.

INPUT CONNECTORS: These are all clearly marked and are all 50K ohms.

GROUND TERMINAL: To be used for "grounding" associated input equipment, such as tonearms, turntables and the like. Should not be connected to tape recorders and/or amplifiers.



"CHASSIS" AND "B-" BANANA JACKS: Special emphasis has been placed in the design of this product to reduce and/or eliminate "hum," "TVI," "RFI" and "CB" type interferences.

For normal use a jumper MUST be placed between these connectors. Otherwise, severe hum and/or oscillation will occur.

Special off-chassis construction is employed to accomplish these interference reduction methods, and this connection is the only one from the "common" or "B-" circuit to the chassis so that it can act as a shield to outside interferences.

For rack cabinet mounting, when ground connections are used (via inputs/outputs), this jumper may be removed to allow only one shield ground path, thereby eliminating what is known as "ground-loop" induced hum. Note that this may or may not necessarily be helpful in a given system.

If your SP-8 is ever removed from the rack, be sure to remember that a jumper MUST be reinstalled.

Discussion, feature and specification sheets are also included herewith to provide you with additional information you may want or need.

A schematic diagram, complete with voltages, references, values, etc., is also included. These three items should provide all the basic information you will need.

#### SERVICING

First of all, a very serious caution: This unit contains over 500 volts of DC, with sufficient voltage and current available to be lethal. So, please, do not poke around inside the unit. Refer any needed service to a qualified technician. (Even with the unit turned off, a charge remains in the energy storage capacitors for some time.)

Basically, this unit is constructed to the highest commercial standards and should require a very minimum amount of service over the years.

The vacuum tubes furnished with your SP-8 are quality tubes, and should not have to be changed for approximately two thousand hours of use. Tubes can fail, however, and the following service hints are offered:

If excessive noise should develop in the phono section only, it is most likely V1.

If degraded sound should occur in the phono section only, it is most likely V2.

V3 is not normally critical, although occasionally excessive hum can be caused by failure of this tube.

If excessive noise develops in the high level section (ie: inputs other than phono), it is most likely V4.

If degraded sound develops in the high level section, it is most likely V5.

V6 is also not normally critical, although it also can introduce hum.

If tube changing is to be done, the unit should be disconnected from the amplifier and turned off while the change is made.

## DISCUSSION OF THE SP-8 MUTING PROVISIONS

The SP-8 has 4 provisions to guard against possible misuse of the exceptional dynamic range and wide bandwidth that it offers. The SP-8 is not subject to damage itself, but some power amplifiers and speakers are more limited in their ability to withstand signal extremes. These provisions, both manual and automatic, are designed to give a flawless listening experience with unprecedented realism, while giving protection against operator error or other improper conditions beyond the operator's control.

1. OUTLET SWITCH to allow the power amplifier to be off during warmup or shutdown of the SP-8. A minimum of 5 minutes warmup time is recommended to insure optimum performance.

2. MUTE/OPERATE SWITCH to manually disable the SP-8 outputs during any moving of the tone arm or switching of equipment. This will minimize stress on your power amplifier even when it is off.

3. WARMUP TIMER that mutes the SP-8 outputs for approximately 2 minutes after the power switch is turned "ON," to ensure circuit stabilization before the outputs come "ON."

4. IMPROVED POWER SUPPLY to tolerate power line disturbances or "brown-outs" down to 100VAC or less, without degradation of circuit performance.

The automatic muting operates as follows:

1. The manual mute switch always disables both outputs and overrides any automatic provisions, even when the SP-8 is turned off. (The "Operate" position of the manual mute switch is functional only after the unit is no longer in automatic mute mode.)

2. The 2-minute warmup timer will restart automatically if the power is temporarily interrupted for 0.2 seconds or more, which is sufficient time to disturb the heater temperature in the tubes.

3. The automatic muting of the SP-8 is designed to be effective only against all kinds of power line interruptions and power supply failures. It will not mute against subsonic signal transmissions from your turntable, etc. Proper fusing of speakers is essential to protect against excessive audio level or power amplifier faults.

4. The muting is accomplished without clicks by "soft-switching" photocouplers, with pure resistive photoconductive elements. No electrical contacts or moving parts are used in the audio path to insure no degradation of sonic performance. All photocoupler lamps are light-emitting diodes to provide essentially infinite service life.

5. Qualified service personnel may wish to disable the warmup muting and output sensor muting for testing purposes. This may be done by reconnecting the output leads to the other side of the photocouplers.

## SUMMARY OF SP-8 FEATURES

As expected with a product of this caliber, the SP-8 offers many outstanding features to the audiophile perfectionist.

AUTOMATIC MUTING: A two-minute warmup timer insures muting of undesirable subsonic output during circuit stabilization. No troublesome relays or electrical contacts are used. (Note that there is no visual indication of automatic muting as, for example, in the SP-6C.)

MANUAL MUTING: A front panel mute switch is included for repeat settings, interruptions, etc.

HIGH ACCURACY, CLOSE TRACKING, SEGMENTED GAIN CONTROL: A metal-film stereo volume control assures trouble free, close tracking volume selection in 2dB steps (guaranteed 1.5dB tracking, .5dB typical).

GAIN "RANGE": An internal wiring change allows for better gain matching or high efficiency loudspeakers, high output cartridges, transformers, etc.

SEPARATE FRONT PANEL POWER RECEPTACLE SWITCH: A front panel switch operates two relay-controlled outlets with a 1600 watt capacity for power amplifiers and other outboard devices.

SPECIAL OFF-CHASSIS CONSTRUCTION: The special isolated ground construction floats all inputs and outputs from the chassis. Special rejection filters are also included to minimize or eliminate RFI, TVI and CB interference.

SONICALLY SELECTED COMPONENTS: Exclusive use of quality tubes, special metal film resistors and multiple shunt capacitors provide optimum sonic accuracy.

OTHER FEATURES INCLUDE: A rear panel provision for disconnecting the common ground from the chassis so that rack mount installations may be accomplished without ground loop induced hum. Front and rear panels are of two-color anodized aluminum construction for permanent finish and lettering. Industrial grade components and construction are used for long service life.

### 3-YEAR LIMITED WARRANTY TERMS AND CONDITIONS

1. LIMITED WARRANTY. Audio Research warrants the product designated herein to be free of manufacturing defects in material and workmanship, subject to the conditions hereinafter set forth, for a period of three (3) years from the date of purchase by the original purchaser or no later than five (5) years from the date of shipment to the authorized Audio Research dealer, whichever comes first, excepting vacuum tubes which are warranted for 90 days only (See 6).
2. CONDITIONS. This Warranty is subject to the following conditions and limitations. The Warranty is void and inapplicable if the product has been used or handled other than in accordance with the instructions in the owner's manual, abused or misused, damaged by accident or neglect or in being transported, or the defect is due to the product being repaired or tampered with by anyone other than Audio Research or an authorized Audio Research repair center. The product must be packed and returned to Audio Research or an authorized Audio Research repair center by the customer at his or her sole expense. Audio Research will pay return freight of its choice. A RETURNED PRODUCT MUST BE ACCOMPANIED BY A WRITTEN DESCRIPTION OF THE DEFECT AND A PHOTOCOPY OF THE ORIGINAL PURCHASE RECEIPT. This receipt must clearly list model and serial number, the date of purchase, the name and address of the purchaser and authorized dealer and the price paid by the purchaser. Audio Research reserves the right to modify the design of any product without obligation to purchasers of previously manufactured products and to change the prices or specifications of any product without notice or obligation to any person.
3. REMEDY. In the event the above product fails to meet the above Warranty and the above conditions have been met, the purchaser's sole remedy under this Limited Warranty shall be to return the product to Audio Research or an authorized Audio Research repair center where the defect will be rectified without charge for parts or labor, except vacuum tubes (See 6).
4. LIMITED TO ORIGINAL PURCHASER. This Warranty is for the sole benefit of the original purchaser of the covered product and shall not be transferred to a subsequent purchaser of the product.
5. DURATION OF WARRANTY. This Warranty expires on the third anniversary of the date of purchase or no later than the fifth anniversary of the date of shipment to the authorized Audio Research dealer, whichever comes first.
6. VACUUM TUBES. Vacuum tubes are warranted for the original 90-day period only.
7. DEMONSTRATION EQUIPMENT. Equipment used by an authorized dealer for demonstration purposes is warranted to be free of manufacturing defects in materials and workmanship for a period of three (3) years from the date of shipment to the dealer. Vacuum tubes are warranted for 90 days. Demo equipment needing warranty service must be packed and returned to Audio Research by the dealer at his sole expense. Audio Research will pay return freight of its choice. A returned product must be accompanied by a written description of the defect on an AUDIO RESEARCH RETURNED GOODS AUTHORIZATION form. Dealer-owned demonstration equipment sold at retail within three (3) years of date of shipment to the dealer is warranted to the first retail customer to be free of manufacturing defects in materials and workmanship for the duration of the 3-Year Limited Warranty remaining (as measured from the date of shipment of the equipment to the dealer). Vacuum tubes are not warranted for any period under these conditions of sale. In the event warranty service is needed under these conditions, the owner of

the equipment must provide a copy of his purchase receipt, fulfilling the requirements described under "2. Conditions" above. The product must be packed and returned to Audio Research or an authorized Audio Research repair center by the customer at his or her sole expense. Audio Research will pay return freight of its choice.

8. MISCELLANEOUS. ANY IMPLIED WARRANTIES RELATING TO THE ABOVE PRODUCT SHALL BE LIMITED TO THE DURATION OF THIS WARRANTY. THE WARRANTY DOES NOT EXTEND TO ANY INCIDENTAL OR CONSEQUENTIAL COSTS OR DAMAGES TO THE PURCHASER. Some states do not allow limitations on how long an implied warranty lasts or an exclusion or limitation of incidental or consequential damages, so the above limitations or exclusions may not apply to you. This Warranty gives you specific legal rights, and you may also have other rights which vary from state to state.

9. WARRANTOR. Inquiries regarding the above Limited Warranty may be sent to the following address:

Audio Research Corporation  
6801 Shingle Creek Parkway  
Minneapolis, MN 55430

#### WARRANTY OUTSIDE THE USA

Audio Research has formal distribution in many of the countries of the free world. In each country the Audio Research Importer has contractually accepted the responsibility for product warranty. Warranty should normally be obtained from the importing dealer or distributor from whom you obtain your product.

In the unlikely event of service need beyond the capability of the Importer, Audio Research does, of course, back up the warranty. Such product would need to be returned to Audio Research, together with a photostatic copy of the bill of sale.

SP-8 SPECIFICATIONS (AC line set @120V 60Hz for these specifications)

Frequency Response:

High level section:  $\pm .25$ dB, 5Hz to 30Hz  
-3dB points below 1Hz and above 100kHz  
Magnetic phono:  $\pm .25$ dB of RIAA, 30Hz to 40kHz

Harmonic Distortion:

Less than .01% at 2V RMS output, 20Hz to 20kHz (Typically less than .0005% in midband)

Intermodulation Distortion:

Less than .002% at 2V RMS output

Gain:

Magnetic phono input to tape output: 34dB      High level inputs to tape output: 0dB  
Magnetic phono input to main output: 60dB      High level inputs to main output: 26dB

Input Impedance:

50K ohms, all inputs (Magnetic phono may have any value from 10 ohms to 100K ohms substituted. Also has provision to add to the 40pF input capacitance for matching certain magnetic cartridges.)

Output Impedance:

1000 ohms main output and tape output. Recommended minimum load for maximum audio quality 20K ohms and .001uF maximum capacitance.

Maximum Inputs:

Magnetic phono, 900mV at 1kHz. (3.5V RMS, 10kHz) High level inputs essentially overload-proof.

Rated Outputs:

2V RMS 5Hz to 30kHz, all outputs; 60K ohm load (main output capability is 60V RMS output at 1/2% THD at 1kHz into a 100K ohm load with 3V RMS high level input)

Power Supplies:

Electronically-regulated supplies utilizing both vacuum tube and solid state elements. Line regulation better than .01%

Noise:

High Level

- (1) 250uV RMS maximum residual unweighted wideband noise at main output with gain control minimum (86dB below 5V RMS output)
- (2) More than 90dB below 1V RMS input (less than 20uV equivalent input noise)

Magnetic Phono

5uV equivalent input noise, wideband RMS (-66dB reference 10mV input)  
(Approximately 1uV above 200Hz or -80dB reference 10mV input)

Tube Complement:

2 - 6DJ8 or equivalent dual triodes      1 - 12BH7A  
4 - reference grade E83CC or equivalent triodes      1 - 12AX7/ECC83

Power Requirements:

100-125VAC 60Hz (190-240VAC 50Hz) 60 Watts

Dimensions:

19" (48 cm) W x 5 1/4" (13.4 cm) H (standard rack panel) x 10 1/4" (26 cm) D.  
Handles extend 1 5/8" (4.1 cm) forward of front panel. Rear chassis fittings extend 7/8" (2.3 cm).

Weight:

22 lbs. (10 kg) Net, 30 lbs. (13.75 kg) Shipping

MODEL SP-8 PREAMPLIFIER

SCHEMATIC & PARTS LIST

7-1-81  
Rev. 1 & 2

**audio research corporation**

6801 SHINGLE CREEK PARKWAY  
MINNEAPOLIS, MINNESOTA 55430



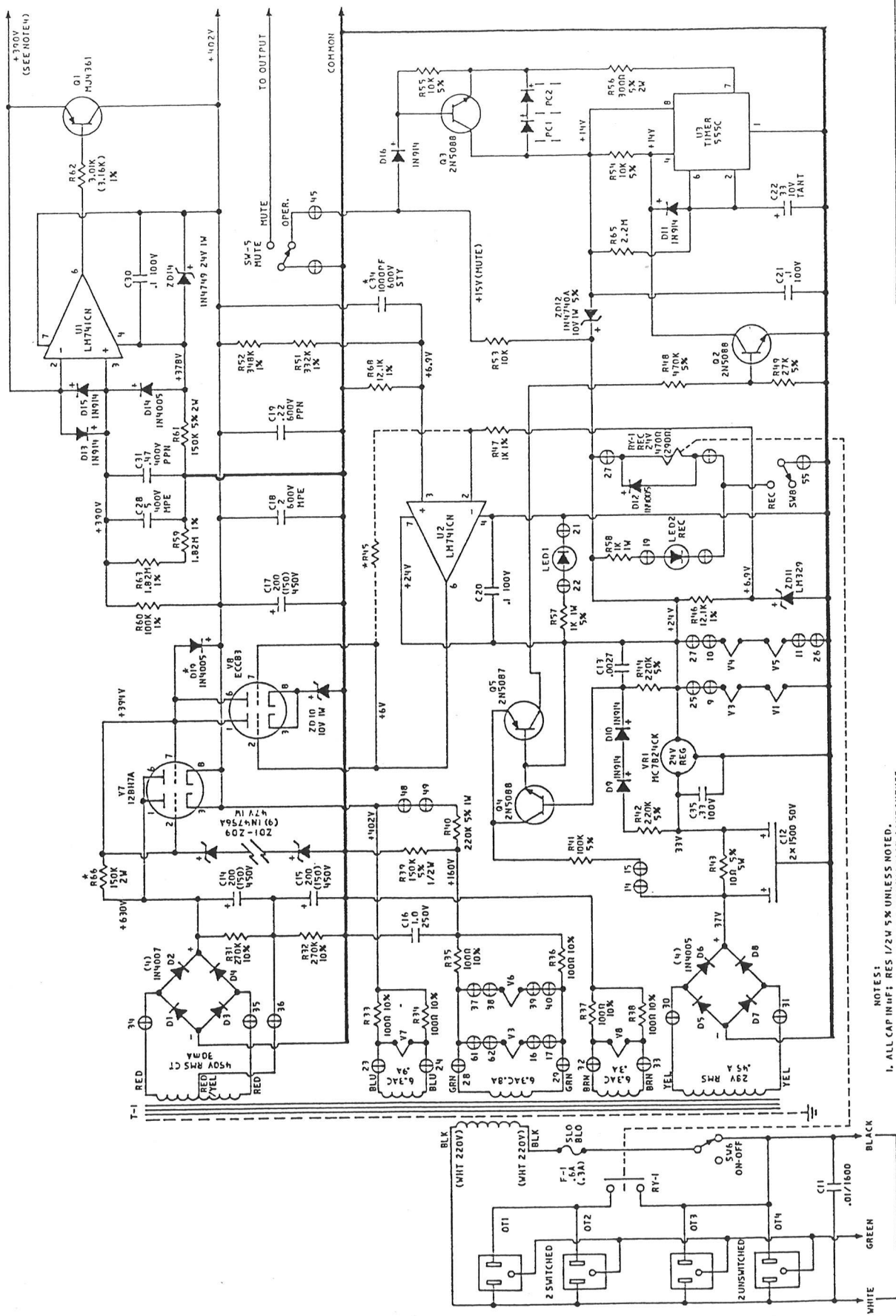

AUDIO RESEARCH CORPORATION MINNEAPOLIS, MINNESOTA	
TITLE	SCHEMATIC
PROJECT	SP-B POWER SUPPLY
DATE	7-1-81
REVISION	910078-10 A

**PROPRIETARY NOTICE**  
 THE INFORMATION CONTAINED HEREIN IS  
 CONSIDERED PROPRIETARY BY AUDIO RESEARCH  
 AND IS FURNISHED ON A CONFIDENTIAL  
 BASIS FOR IDENTIFICATION PURPOSES ONLY.

- NOTES:
1. ALL CAP IN 1/2% 5% UNLESS NOTED.
  2. USE CAUTION WHEN SERVICING HIGH VOLTAGE COMPONENTS. CONTACT WITH STORED ENERGY EVEN WITH POWER OFF COULD BE LETHAL.
  3. ALL VOLTAGES AT 120VAC 60HZ LINE.
  4. BE SURE DC VOLTAGES THRU 1KΩ ISOLATION RESISTOR TO MINIMIZE CAPACITIVE LOADING EFFECTS.
  5. \* EFFECTIVE OCT/81 SONIC AND RELIABILITY IMPROVEMENT: ADDED C34 AND D19, R66 24W AS 1/24W, R45 DELETED WAS 100K. LITZ WIRE ADDED.

*REV 1 + 2*



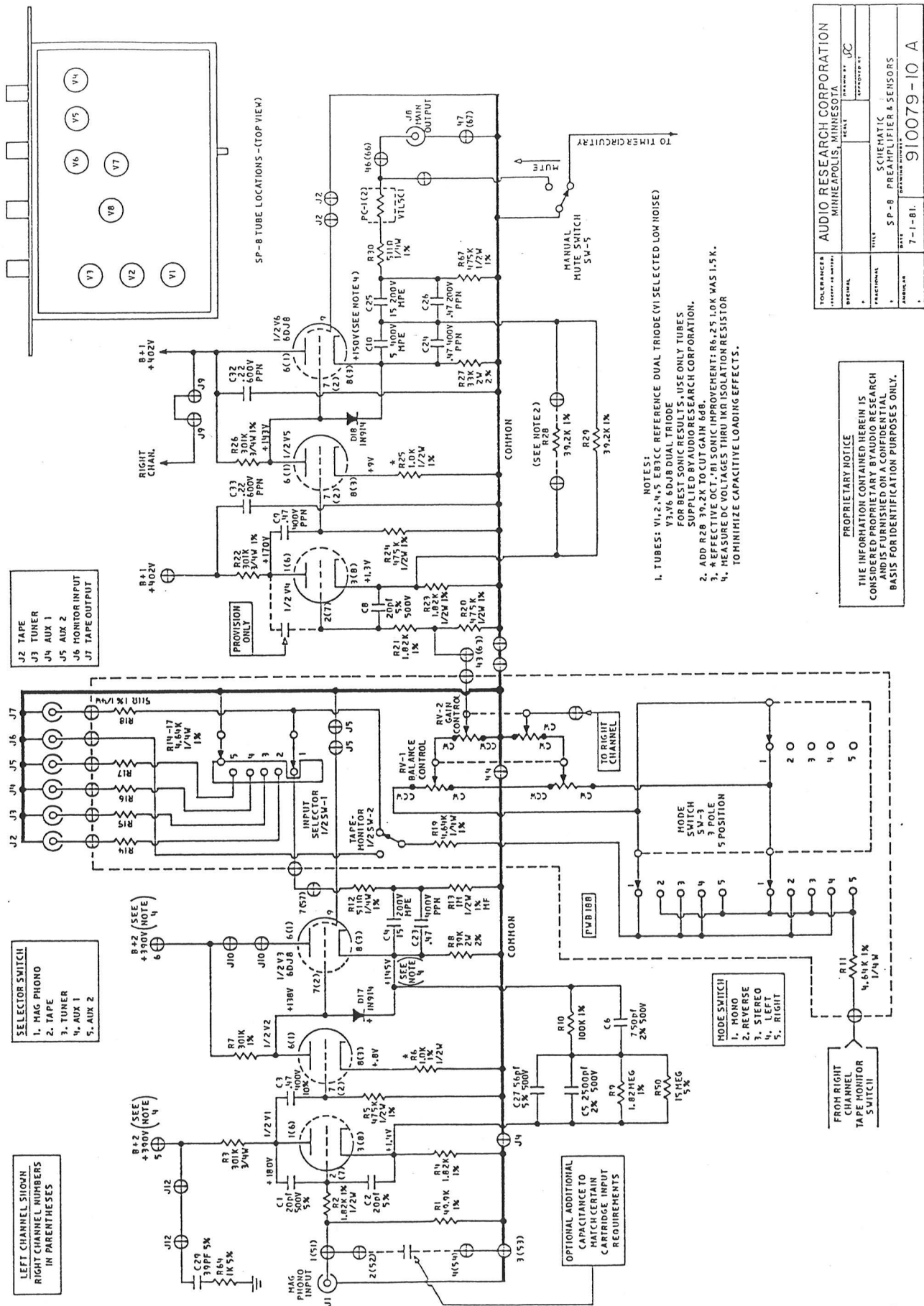

LEFT CHANNEL SHOWN  
RIGHT CHANNEL NUMBERS  
IN PARENTHESES

SELECTOR SWITCH  
1. MAG PHONO  
2. TUNER  
3. TAPE  
4. AUX 1  
5. AUX 2

J2 TAPE  
J3 TUNER  
J4 AUX 1  
J5 AUX 2  
J6 MONITOR INPUT  
J7 TAPE OUTPUT

SP-8 TUBE LOCATIONS - (TOP VIEW)

- NOTES:
1. TUBES: V1, 2, 4, 5 6BC6 REFERENCE DUAL TRIODE (V1 SELECTED LOW NOISE)  
V3, V6 6D8 DUAL TRIODE  
FOR BEST SOUND RESULTS - USE ONLY TUBES  
SUPPLIED BY AUDIO RESEARCH CORPORATION.
  2. ADD R28 470K TO C6 FOR TONE IMPROVEMENT; R6, 25.10K WAS 1.5K.
  3. REFERENCE TO C6 FOR TONE IMPROVEMENT; R6, 25.10K WAS 1.5K.
  4. MEASURE DC VOLTAGES THRU 1KΩ ISOLATION RESISTOR  
TO MINIMIZE CAPACITIVE LOADING EFFECTS.

PROPRIETARY NOTICE  
THE INFORMATION CONTAINED HEREIN IS  
CONSIDERED PROPRIETARY BY AUDIO RESEARCH  
AND IS FURNISHED ON A CONFIDENTIAL  
BASIS FOR IDENTIFICATION PURPOSES ONLY.

TOLERANCES UNLESS OTHERWISE SPECIFIED	AUDIO RESEARCH CORPORATION MINNEAPOLIS, MINNESOTA
DESIGNER	SCALE
PREPARED BY	APPROVED BY
TITLE	SCHEMATIC
DATE	7-1-61
PART NUMBER	910079-10 A

SP-8 PARTS LIST

SP-8 PARTS LIST

COMPONENT	QUAN.	DESCRIPTION	VALUE	RATING	TOL.	ARC PART NO.
V1,2,4,5	4	E83CC Reference				
V3,6	2	6DJ8				32001000
V7	1	12BH7A				32001100
V8	1	EC83/12AX7A				32001200
D1-4	4	IN4007(1N4006)	1A	1000V		32001000
D5-8,12,14,19	7	IN4005	1A	600V		30501000
D9-11,13,15-18	10	IN914		100V		30500400
ZD1-9	9	IN4756A Zener		1W		30500900
ZD10,12	2	IN4740A Zener		1W		30503200
ZD11	1	LM3290Z Zener Ref.		1W		30500300
ZD14	1	IN4749 Zener		6.9V		31000700
LED 1,2	2	LED Green		24V		30502500
Q1	1	M4361 Transistor				34300100
Q2,3,4	3	2N5088 Transistor				30004400
O5	1	2N5087 Transistor				30003100
RV1	1	Balance Control	100K	10%		30003000
RV2	1	Gain Control	100K	10%		45100525
VR1	1	MC7824CK	24V	LogTaper		45100525
U1,U2	1	LM741CN		1A		31001200
U3	1	LN555CN Timer				31000400
PC1,2	2	VTL5C1 Photo Coupler				31000800
R1	2	Metal Film	49.9K	100V		34400100
R2,4,21,23	8	Metal Film	1.82K	1/2W	1%	42499403
R3,7,22,26	8	Metal Film	301K	1/2W	1%	42182303
R5,20,24,67	8	Metal Film	475K	3/4W	1%	42301504
R6,25	4	Metal Film	1.0K	1/2W	1%	42475503
R8	2	Metal Film	1.5K	1/2W	1%	42100303
R9,59,63	4	Metal Film	39K	2W	2%	46350401
R10,60	3	Metal Film	1.82Meg	1/2W	1%	42182603
R11,14-17,19	10	Metal Film	100K	1/2W	1%	42100503
R12,18,30	6	Metal Film	4.64K	1/4W	1%	42464302
R13	2	Metal Film	510R	1/4W	1%	42511202
R27	2	Metal Film	33K	1/2W	2%	46330401
R29(R28)	2	Metal Film	39.2K	1/2W	1%	42392403
R31,32	2	Carbon	270K	2W	10%	40270505
R33-38	6	Carbon	100R	1/2W	10%	40270505
R39	1	Carbon	150K	1/2W	5%	41150503
R40	1	Carbon	220K	1W	5%	41220504
R41	1	Carbon	100K	1/4W	5%	41100502
R42,44	2	Carbon	220K	1/4W	5%	41220502
R43	1	Wirewound	10R	5W	5%	43100104
R45	2	Metal Film	100K	1/4W	1%	42100502
R46,68	2	Metal Film	12.1K	1/2W	1%	42121403
R47	1	Metal Film	1K	1/4W	1%	42100302
R48	1	Carbon	470K	1/4W	5%	41470502
R49	1	Carbon	27K	1/4W	5%	41270402
R50	2	Carbon	15Meg	1/2W	5%	41150703
R51	1	Metal Film	332K	1/2W	1%	42332503
R52	1	Metal Film	348K	1/2W	1%	42348503
R53,54,55	3	Carbon	10K	1/4W	5%	41100402
R56	1	Wirewound (M. Film)	300R	2W	5%	43300200
R57,58	2	Carbon	1K	1W	5%	41100304
R61,66	2	Carbon	150K	2W	5%	41150505
R62	1	Metal Film	150K	1/2W	1%	42150503
R64	1	Metal Film	3.01K	1/2W	1%	42301303
R65	1	Carbon	1K	1/4W	5%	41100302
C1,2,8	6	Dipped Mica	2.2Meg	1/4W	5%	41220602
C3,9	4	Polypropylene	20pF	500V	5%	57200100
C4,25	4	Polyester	.47uF	400V	20%	53470506
C5	2	Dipped Mica	15uF	200V	20%	53150700
C6	2	Dipped Mica	2500pF	500V	2%	57250301
C10,28	3	Polyester	750pF	500V	2%	57750201
C11	1	Polyester	5uF	400V	10%	53500602
C12	1	Electrolytic	.01uF	1600V	10%	53100403
C13	1	Polyester	2x1500uF	50V		50150900
C14,15,17	3	Electrolytic	.0027uF	200V	10%	53270301
C16	1	Polypropylene	(150)200uF	450V		50200801
C18	1	Polyester	1.0uF	250V	20%	53100606
C19,32,33	3	Polypropylene	.22uF	600V	10%	53200600
C20,21,30	3	Ceramic Monolythic	.1uF	600V	10%	53220505
C22	1	Dipped Tantalum	33uF	10V	10%	52100500
C23,24,31	5	Polypropylene	.47uF	400V	20%	53470505
C26	2	Polypropylene	.47uF	200V	20%	53470507
C27	2	Dipped Mica	56pF	500V	5%	57560100
C29	1	Polystyrene	39pF	500V	5%	57390100
C34	1	Polypropylene	1000pF	600V	5%	53100301
C35	1	Ceramic Monolythic	.33uF	100V	20%	52330500
F1	1	Sto-Blo 120V	0.6A	250V		34500220
T1	1	Transformer	0.3A	250V		34500120
OT1-4	4	Transformer		120V		60004402
SW1	1	Input Selector Switch	2Pole	5Pos		23201300
SW2	1	Tape Monitor Switch	DPDT	Gold		24001000
SW3	1	Mode Switch	3Pole	5Pos		24000700
SW5	1	Mute-Operate Switch	DPDT	Gold		24100400
SW6,8	1	On-Off Switch	DPDT	Gold		24100700
RY-1	1	Relay, 24V	DPDT	Silver		64100300
VI-J16	16	Phono Jack	SPST	N.O.		23201000

MODEL SP-8 PREAMPLIFIER  
SCHEMATIC

REV. 3  
7-1-83

**audio research corporation**

6801 SHINGLE CREEK PARKWAY  
MINNEAPOLIS, MINNESOTA 55430

**PROPRIETARY NOTICE**  
THE INFORMATION CONTAINED HEREIN IS  
CONSIDERED PROPRIETARY BY AUDIO RESEARCH  
AND IS FURNISHED ON A CONFIDENTIAL  
BASIS FOR IDENTIFICATION PURPOSES ONLY.

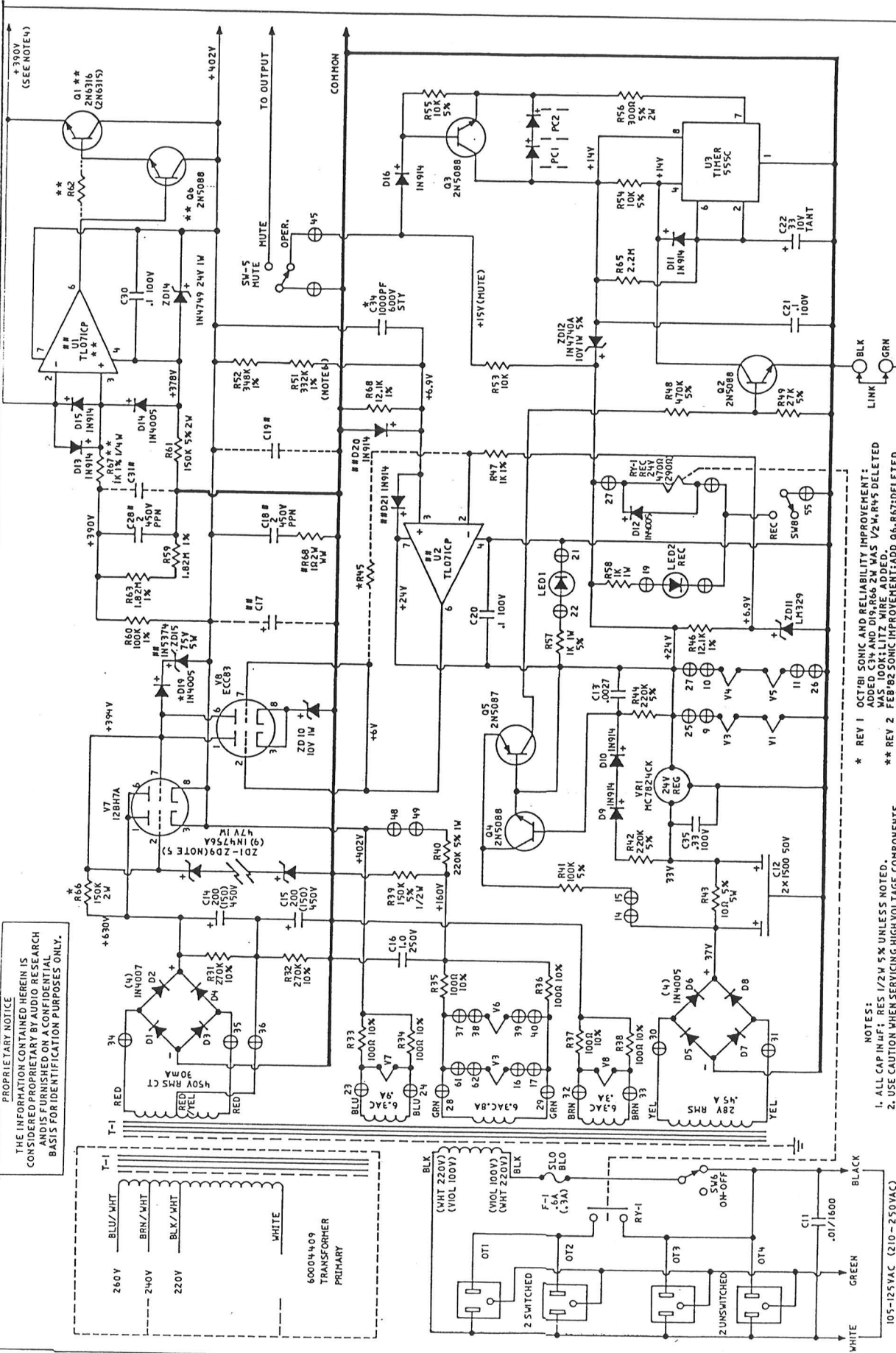

TOLERANCES		AUDIO RESEARCH CORPORATION	
RESISTORS	1%	MINNEAPOLIS, MINNESOTA	SCALE
CAPACITORS	5%	MINNEAPOLIS, MINNESOTA	APPROVED BY
		TITLE	SCHEMATIC
		DATE	7-1-83
		SP-8 POWER SUPPLY	
		DRAWING NUMBER	
		910078-10 B	

- NOTES:**
- ALL CAP IN 1/4 W. RES 1/2 W 5% UNLESS NOTED.
  - USE CAUTION WHEN SERVICING HIGH VOLTAGE COMPONENTS. CONTACT WITH STORED ENERGY EVEN WITH POWER OFF COULD BE LETHAL.
  - ALL VOLTAGES AT 120VAC 60Hz LINE. TO MINIMIZE CAPACITIVE LOADING EFFECTS.
  - FORMAL ADDITIONAL IN4756A (10 TOTAL) TO ENSURE AT LEAST 3000 PPM OF 600V WITH 'V6' REMOVED.
  - R51 MAY BE 3/4W OR 3/1W TO TRIM +402V WITH SOME ZD11.
- REV 1** OCT-81 SONIC AND RELIABILITY IMPROVEMENT: ADDED C34 AND D19. R66 2M WAS 1/2W. R45 DELETED WAS 100K. LITZ WIRE ADDED.  
**REV 2** FEB-82 SONIC IMPROVEMENT: ADD 66. R67 DELETED WAS 1/4W. R41 WAS HJ-9361 OR 2N4231A(1)  
**REV 3** REL-CAP MAY-82 SONIC IMPROVEMENT: ADD R61C18 WAS 7.1E 600V. C19 WAS .22UF 600V. ZD11 WAS 50V SONIC AND RELIABILITY IMPROVEMENT: ADDED ZD11. C19 WAS 220UF 50V. C17 WAS 600UF 450V.

TOLERANCES		AUDIO RESEARCH CORPORATION	
RESISTORS	1%	MINNEAPOLIS, MINNESOTA	SCALE
CAPACITORS	5%	MINNEAPOLIS, MINNESOTA	APPROVED BY
		TITLE	SCHEMATIC
		DATE	7-1-83
		SP-8 POWER SUPPLY	
		DRAWING NUMBER	
		910078-10 B	

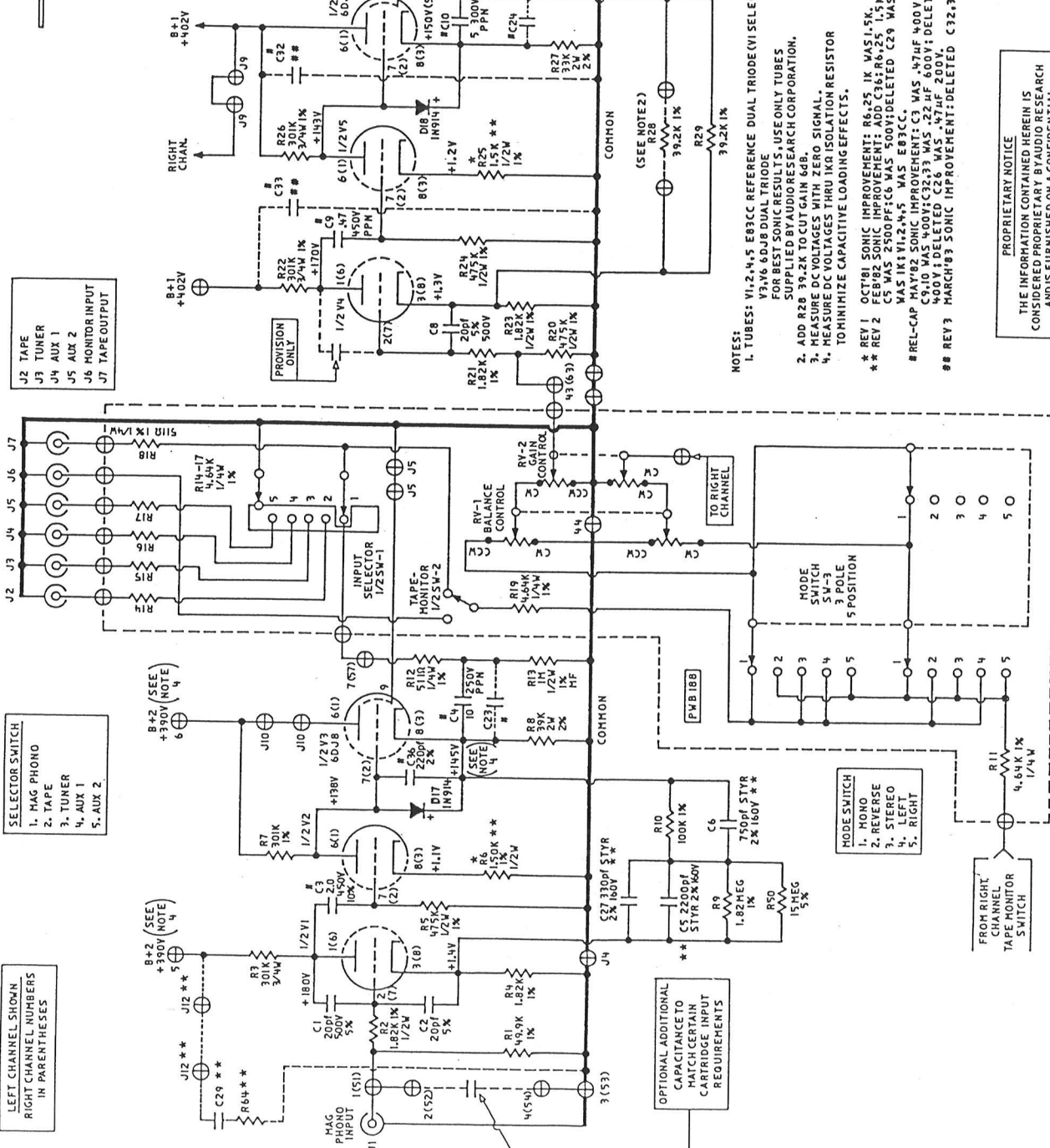
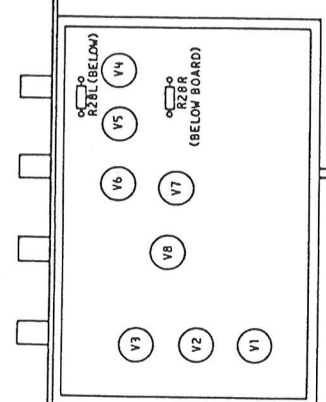

LEFT CHANNEL SHOWN  
RIGHT CHANNEL NUMBERS  
IN PARENTHESES

SELECTOR SWITCH  
1. MAG PHONO  
2. TAPE  
3. TUNER  
4. AUX 1  
5. AUX 2

MAG PHONO INPUT (51)  
J1  
J2  
J3  
J4  
J5  
J6  
J7  
J8  
J9  
J10

NOTES:  
1. TUBES: V1,2,4,5 EB3CC REFERENCE DUAL TRIODE (V1 SELECTED LOW NOISE)  
V3, V6 6DJ8 DUAL TRIODE  
FOR BEST SONIC RESULTS, USE ONLY TUBES  
SUPPLIED BY AUDIO RESEARCH CORPORATION.  
2. ADD R28 39.2K TO CUT GAIN 6dB.  
3. MEASURE DC VOLTAGES WITH ZERO SIGNAL.  
4. MEASURE DC VOLTAGES THRU 1KΩ ISOLATION RESISTOR  
TO MINIMIZE CAPACITIVE LOADING EFFECTS.

\*\* REV 1 OCT'81 SONIC IMPROVEMENT: R6, 25.1K WAS 1.0K; C27 WAS 58PFF  
REV 2 SONIC IMPROVEMENT: R6, 25.1K WAS 1.0K; C27 WAS 58PFF  
C5 WAS 2500PF; C6 WAS 500V; DELETED C29 WAS 56PFF; DELETED R6  
WAS 1K; V1, 2, 4, 5 WAS EB3CC.  
# REL-CAP MAY-82 SONIC IMPROVEMENT: C3 WAS .47µF 400V; C4, 25 WAS 15µF 200V;  
C9, 10 WAS 400V; C23, 33 WAS .22µF 600V; DELETED C23, 24 WAS .47µF  
400V; DELETED C26 WAS .47µF 200V.  
## REV 3 MARCH-83 SONIC IMPROVEMENT: DELETED C32, 33 WAS .47µF 450V.

PROPRIETARY NOTICE  
THE INFORMATION CONTAINED HEREIN IS  
CONSIDERED PROPRIETARY BY AUDIO RESEARCH  
AND IS FURNISHED ON A CONFIDENTIAL  
BASIS FOR IDENTIFICATION PURPOSES ONLY.

AUDIO RESEARCH CORPORATION MINNEAPOLIS, MINNESOTA	
TOLERANCES UNLESS OTHERWISE SPECIFIED	RESISTORS BY JC
CAPACITORS BY JC	INDUCTORS BY JC
FRONT PANEL BY JC	SCHEMATIC
DATE 7-1-83	SP-8 PREAMPLIFIER & SENSORS
REV 3	910079-10 B

SP-8 PREAMPLIFIER  
SCHEMATIC & PARTS LIST

Rev. E  
4-4-84

**audio research corporation**

6801 SHINGLE CREEK PARKWAY  
MINNEAPOLIS, MINNESOTA 55430

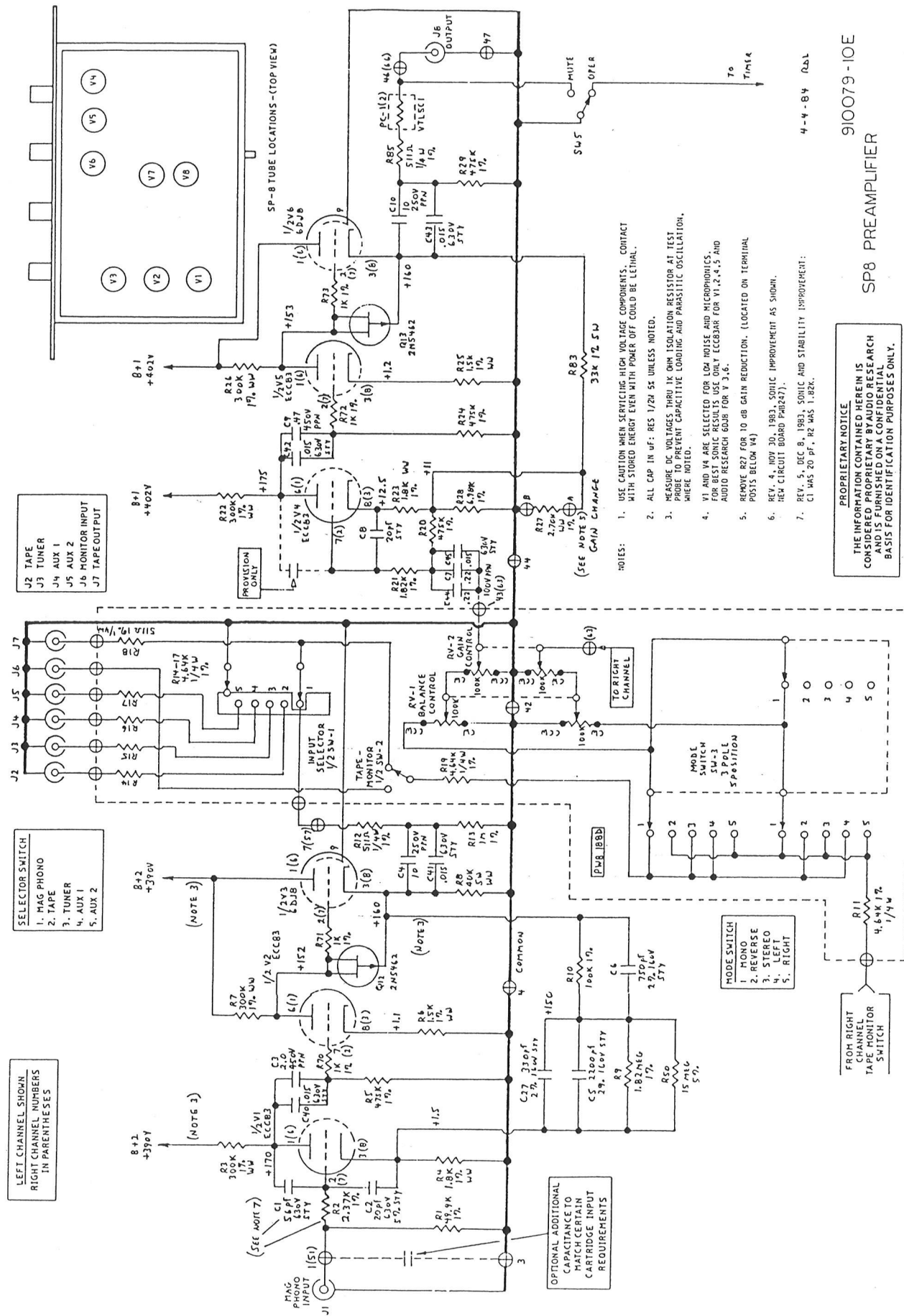

LEFT CHANNEL SHOWN  
RIGHT CHANNEL NUMBERS  
IN PARENTHESES

SELECTOR SWITCH  
1. MAG PHONO  
2. TAPE  
3. TUNER  
4. AUX 1  
5. AUX 2

J2 TAPE  
J3 TUNER  
J4 AUX 1  
J5 AUX 2  
J6 MONITOR INPUT  
J7 TAPE OUTPUT



- NOTES:
1. USE CAUTION WHEN SERVICING HIGH VOLTAGE COMPONENTS. CONTACT WITH STORED ENERGY EVEN WITH POWER OFF COULD BE LETHAL.
  2. ALL CAP IN  $\mu$ F: RES 1/2W 5% UNLESS NOTED.
  3. MEASURE DC VOLTAGES THRU 1K OHM ISOLATION RESISTOR AT TEST PROBE TO PREVENT CAPACITIVE LOADING AND PARASITIC OSCILLATION, WHERE NOTED.
  4. V1 AND V4 ARE SELECTED FOR LOW NOISE AND MICROPHONICS. FOR BEST SONIC RESULTS USE ONLY ECC83AR FOR V1, 2, 4, 5 AND AUDIO RESEARCH 600B FOR V3, 6.
  5. REMOVE R27 FOR 10 DB GAIN REDUCTION. (LOCATED ON TERMINAL POSTS BELOW V4)
  6. REV. 4, NOV 30, 1983, SONIC IMPROVEMENT AS SHOWN. (NEW CIRCUIT BOARD PH2427).
  7. REV. 5, DEC 8, 1983, SONIC AND STABILITY IMPROVEMENT: C1 WAS 20 PF, R2 WAS 1.82K.

PROPRIETARY NOTICE  
THE INFORMATION CONTAINED HEREIN IS  
CONSIDERED PROPRIETARY BY AUDIO RESEARCH  
AND IS FURNISHED ON A CONFIDENTIAL  
BASIS FOR IDENTIFICATION PURPOSES ONLY.

PROPRIETARY NOTICE  
 THE INFORMATION CONTAINED HEREIN IS  
 CONSIDERED PROPRIETARY BY AUDIO RESEARCH  
 AND IS FURNISHED ON A CONFIDENTIAL  
 BASIS FOR IDENTIFICATION PURPOSES ONLY.

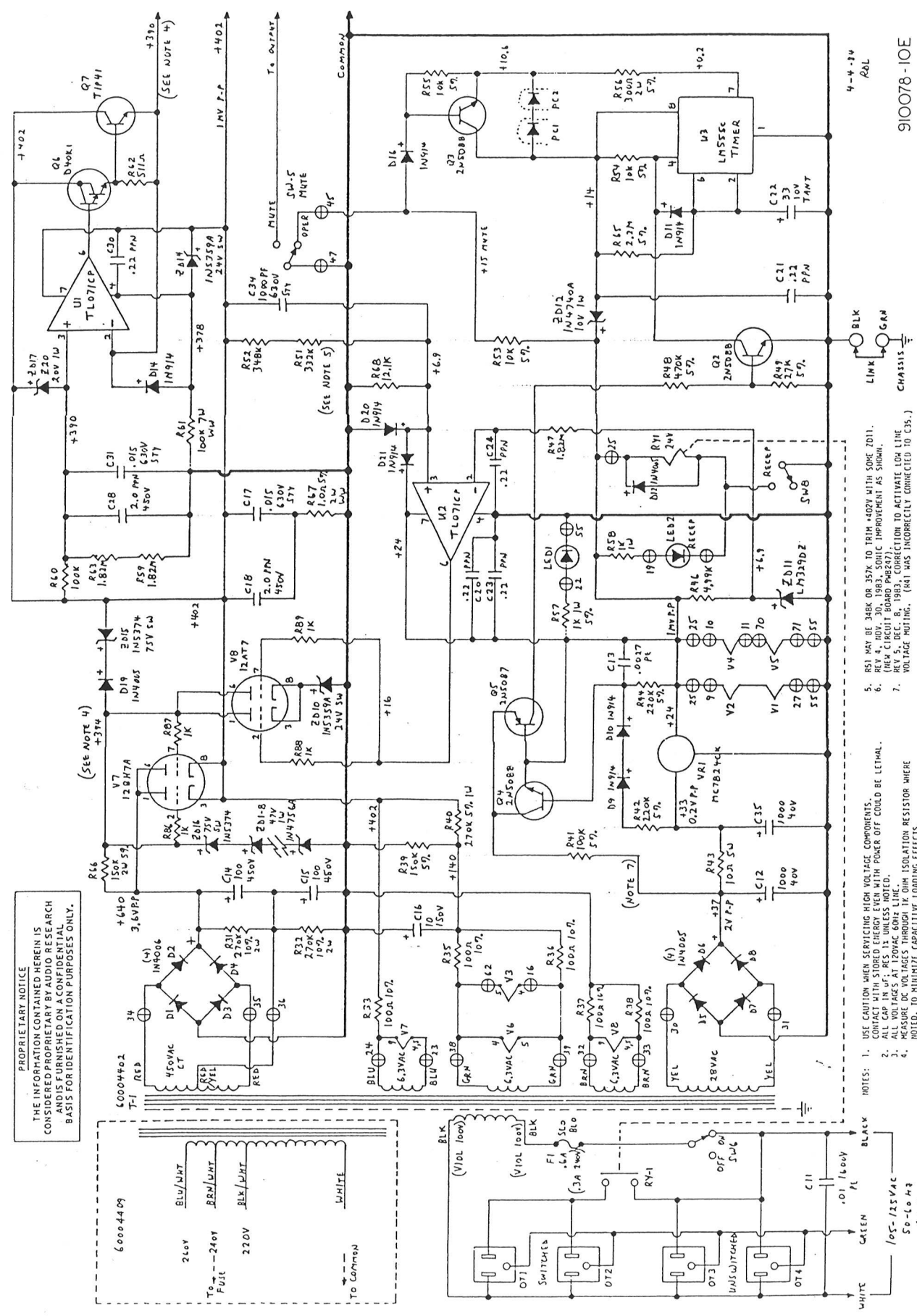

- NOTES:
1. USE CAUTION WHEN SERVICING HIGH VOLTAGE COMPONENTS. CONTACT WITH STORED ENERGY EVEN WITH POWER OFF COULD BE LETHAL.
  2. ALL CAPACITORS ARE 5% UNLESS NOTED.
  3. ALL CAPACITORS ARE 5% UNLESS NOTED.
  4. MEASURE DC VOLTAGES THROUGHOUT THE CHIM ISOLATION RESISTOR WHERE NOTED, TO MINIMIZE CAPACITIVE LOADING EFFECTS.
  5. R51 MAY BE 348K OR 357K TO TRIM +402V WITH SORE ZD11.
  6. (REV 4, NOV. 30, 1983, SONIC IMPROVEMENT AS SHOWN).
  7. (REV 5, DEC. 8, 1983, CORRECTION TO ACTIVATE LOW LINE VOLTAGE ROUTING. (PART WAS INCORRECTLY CONNECTED TO C35.))



SP-8 PARTS LIST

COMPONENT	QUAN.	DESCRIPTION	VALUE	RATING	TOL.	ARC PART NO.
V1,2,4,5	4	EC83AR				32001300
V3,6	2	6DJB				32001100
V7	1	12BH7A				32001200
V8	1	12AT7				32000900
D1-4	4	1N4006	1A	800V		30502200
D5-8,12,19	6	1N4005	1A	600V		30500400
D9,10,11,14,16	7	1N914		100V		30500900
Z0,21	8	1N4756A Zener	47V	1W		30503200
ZD1-8	2	1N5359A Zener	24V	5W		30503500
ZD10,14	1	1N4329DZ Zener Ref.	6.9V			31000700
ZD11	1	1N4329DZ Zener	10V	1W		30500300
ZD12	2	1N4740A Zener	75V	5W		30502900
ZD15,16	2	1N5374A Zener	20V	1W		30503700
ZD17	1	Z0 Zener				34300100
LED1,2	2	LED Green				30003100
Q2,3,4	3	2N5088 Trans	NPN			30003000
Q5	1	2N5087 Trans	PNP			30003000
Q6	1	D4QK1 Trans	Dar1 NPN			30005200
Q7	1	T1P41 Trans				30005000
Q12, 13	4	2N5462 FET	P-Chan			30005900
RV1	1	Balance Control	100K	LinTaper	10%	45100525
RV2	1	Gain Control	100K	LogTaper	10%	45100528
VR1	1	MC7824CK	24V	1A		31001200
U1,2	2	TL071CP Op Amp				31001900
U3	1	LM555CN Timer				31000800
PC1,2	2	VTL5C1 Photocoupler				34400100
R1	2	Metal Film	49, 9K	1/2W	1%	42499403
R2	2	Metal Film	2.37K	1/4W	1%	42237302
R3,7,22,26	8	Metal Film	1.82K	1/2W	1%	42182303
R4,23	4	Wirewound	300K	0.2W	1%	43300501
R5,20,24,29	8	Metal Film	1.8K	1W	1%	43182300
R6,25	4	Wirewound	475K	1/2	1%	42475503
R8	2	Wirewound	1.5K	2W	1%	43150302
R9,47,59,63	5	Metal Film	40K	5W	3%	43400400
R10,60	3	Metal Film	1.82Meg	1/2W	1%	42182603
R11,14-17,19	10	Metal Film	100K	1/2W	1%	42100503
R12,18,62,85	7	Metal Film	4.64K	1/4W	1%	42464302
R13	2	Metal Film	511	1/4W	1%	42511202
R21	2	Metal Film	1Meg	1/2W	1%	42100603
R27	2	Metal Film	1.82K	1/2W	1%	42182303
R28	2	Wirewound	2.70K	2W	1%	43270301
R31,32	2	Metal Film	6.98K	1/2W	1%	42698303
R33,35-38	5	Carbon	270K	2W	10%	40270505
R39	1	Carbon	100	1/2W	10%	40100203
R40	1	Carbon	150K	1/2W	5%	41150503
R41	1	Carbon	270K	1W	5%	41270504
R42,44	2	Carbon	100K	1/4W	5%	41100502
R43	2	Carbon	220K	1/4W	5%	41220502
R46	1	Wirewound	10	5W	5%	43100104
R48	1	Metal Film	4.99K	1/2W	1%	42499303
R49	1	Carbon	470K	1/4W	5%	41470502
R50	2	Carbon	27K	1/4W	5%	41270402
R51	1	Carbon	15Meg	1/2W	5%	41150703
R52	1	Metal Film	332K	1/2W	1%	42332503
R53-55	3	Carbon	348K	1/2W	1%	42348503
			10K	1/4W	5%	41100402

SP-8 PARTS LIST

COMPONENT	QUAN.	DESCRIPTION	VALUE	RATING	TOL.	ARC PART NO.
R56	1	Wirewound (M. Film)	300	2W	5%	43300200
R57,58	2	Carbon	1K	1W	5%	41100304
R61	1	Wirewound	100K	7W	5%	41100500
R65	1	Carbon	2.2Meg	1/4W	5%	41220602
R66	1	Metal Film	150K	2W	2%	46150500
R67	1	Wirewound	1.0	2W	5%	43100002
R68	1	Metal Film	12.1K	1/2W	1%	42121403
R70,71,86,87	6	Metal Film	1K	1/4W	1%	42100302
R72,73,88,89	6	Metal Film	1K	1/2W	1%	42100303
R83	2	Wirewound	33K	5W	1%	43330400
C1	2	Polystyrene	56pF	630V	2.5%	53560102
C2,8	4	Polystyrene	20pF	630V	5%	53200101
C3,18,28	4	Polystyrene	20pF	630V	5%	53200101
C4,10	4	Polypropylene	2uF	450V	10%	53200602
C5	4	Polypropylene	10uF	250V	10%	53100700
C6	2	Polystyrene	220pF	160V	2.5%	53220302
C7,20,21,23	2	Polystyrene	750pF	160V	2.5%	53750200
C24,30,44	9	Polypropylene	.22uF	100V	10%	53220506
C9	2	Polypropylene	.47uF	450V	10%	53470509
C11	1	Polyester	.01uF	1600V	10%	53100403
C12,35	2	Electrolytic	1000uF	40V		50100904
C13	1	Polyester	.0027uF	200V	10%	53270301
C14,15	2	Electrolytic	100uF	450V		50100802
C16	1	Electrolytic	10uF	150V		50100703
C17,31,40-43,45	12	Polystyrene	.015uF	630V	5%	53150404
C22	1	Tantalum	33uF	10V	10%	51330700
C27	2	Polystyrene	330pF	160V		53330200
C34	1	Polystyrene	1000pF	630V	2.5%	53100301
F1	1	Fuse, S10-D10	0.6A	250V		34500020
T1	1	Transformer	0.3A	250V		34500020
		Transformer		120V		60004402
		Transformer		100V		60004403
		Transformer		240V		60004409
OT1-4	4	AC Receptacle				23201300
SW1	1	Input Selector Sw.	2Pole	5Position		24001000
SW2	1	Tape Monitor Sw.	DPDT	Gold		24100400
SW3	1	Mode Switch	3Pole	5Position		24000700
SW5	1	Mute-Operate Sw.	DPDT	Gold		24100400
SW6	1	On-Off Switch	DPDT	Silver		24100700
SW8	1	Receptacle Sw.	DPDT	Silver		24100700
RY1	1	Relay 24V	SPST	N.O.		64100600
J1-J16	16	Phono Jack				23201000

NOTE: Resistor values are in "ohms" except "K" = x 1,000; "Meg" = x 1,000,000